

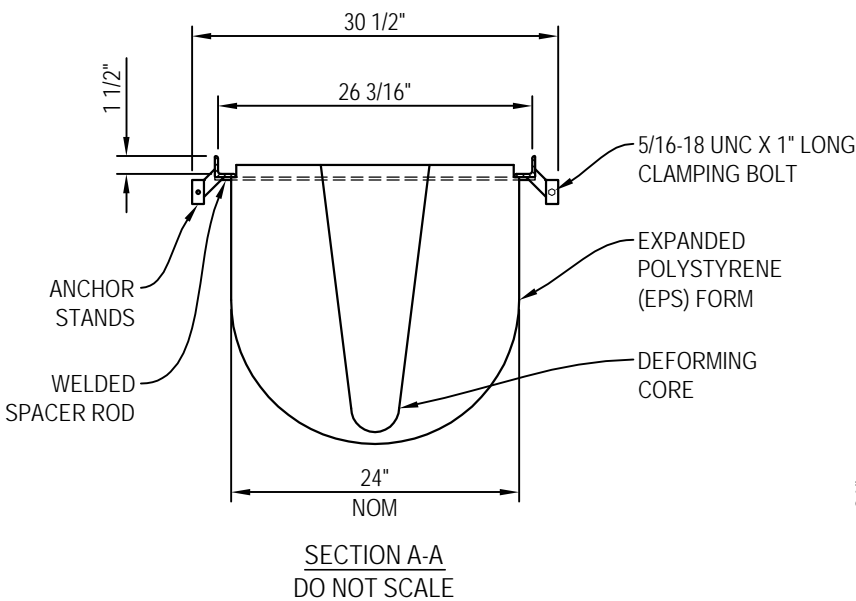

We Drain Your Site, Not Your Budget!

MULTIDRAIN SYSTEMS, INC.  
P.O. BOX 88  
BARIUM SPRINGS, NC 28010  
TOLL FREE: 1-800-433-1119  
PHONE: (704) 508-1010  
FAX: (704) 508-1011  
www.multidrain.com

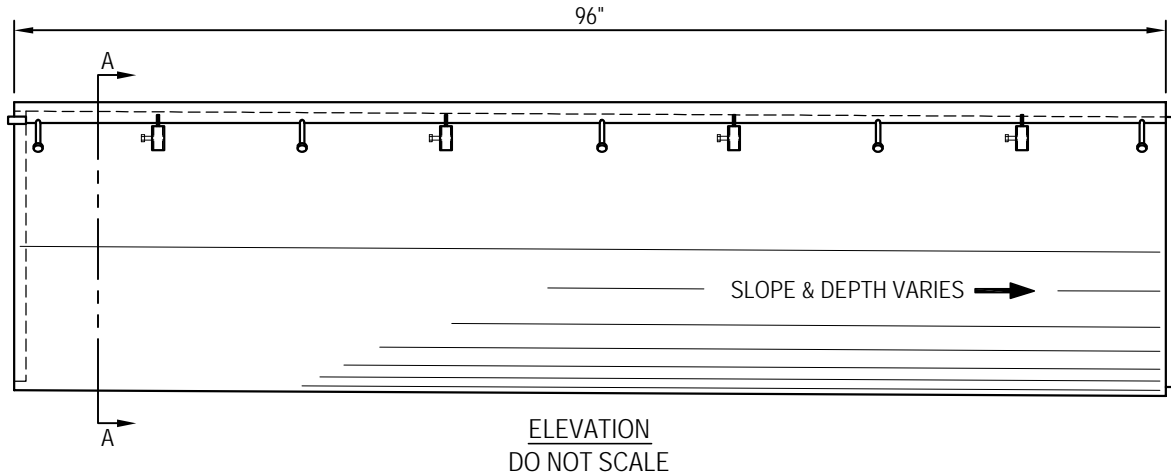

**FINISH SPECIFICATION**  
GRATE FRAME: BLACK PAINT - STANDARD  
HOT DIP GALVANIZE - OPTIONAL  
CAST GRATE : BLACK PAINT - STANDARD  
HOT DIP GALVANIZE - OPTIONAL

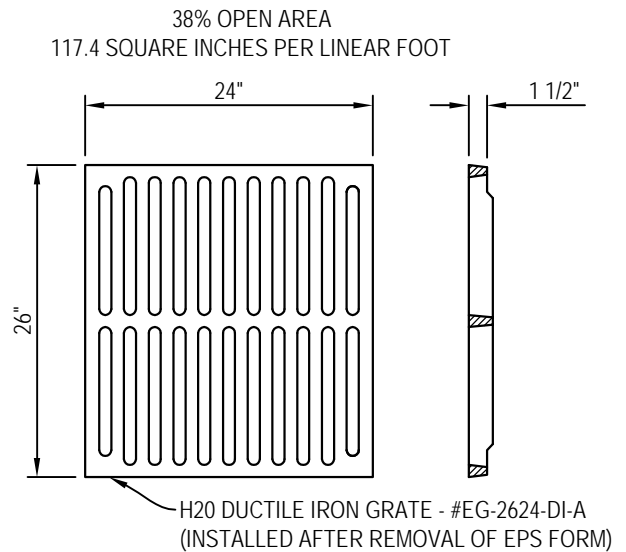

**NOTES:**

- 1. INSTALLATION TO BE COMPLETED IN ACCORDANCE WITH MANUFACTURERS SPECIFICATIONS.
- 2. DO NOT SCALE DRAWINGS.

 EconoDrain® Series #24  
DUCTILE IRON GRATE (STANDARD)